

技術數據

Vertical Multistage Centrifugal In-line Pumps



STAIRS PUMPS

尺寸和重量-SB20

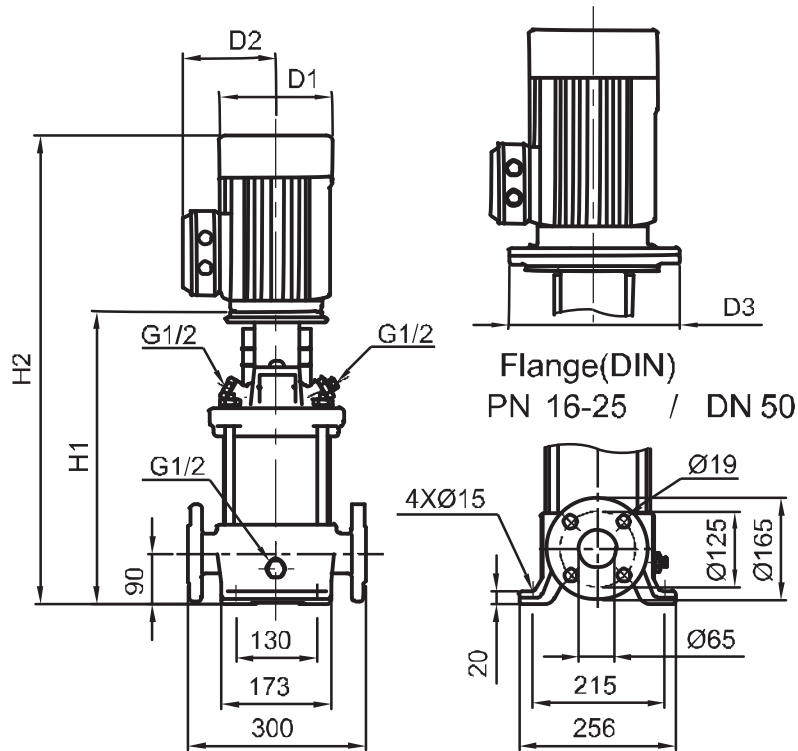

泵浦型號	電機 P ₂ [KW]	SB					
		尺寸 (mm)				淨重 (kg)	
		DIN flange		D1	D2	D3	DIN flange
H1	H2						
SB20-1	1.1	400	631	141	109	—	42
SB20-2	2.2	415	690	175	140	—	52.7
SB20-3	4	465	800	219	162	—	68.4
SB20-4	5.5	542	902	234	199	300	93.6
SB20-5	5.5	587	947	234	199	300	95.0
SB20-6	7.5	632	1032	234	199	300	105.4
SB20-7	7.5	677	1077	234	199	300	106.8
SB20-8	11	799	1244	268	215	350	137.9
SB20-10	11	889	1334	268	215	350	140.7
SB20-12	15	979	1468	268	215	350	154.5
SB20-14	15	1069	1558	268	215	350	157.3
SB20-17	18.5	1204	1739	317	242	350	196.4

技術數據

Vertical Multistage Centrifugal In-line Pumps



STAIRS PUMPS

尺寸和重量-SBI,SBN20

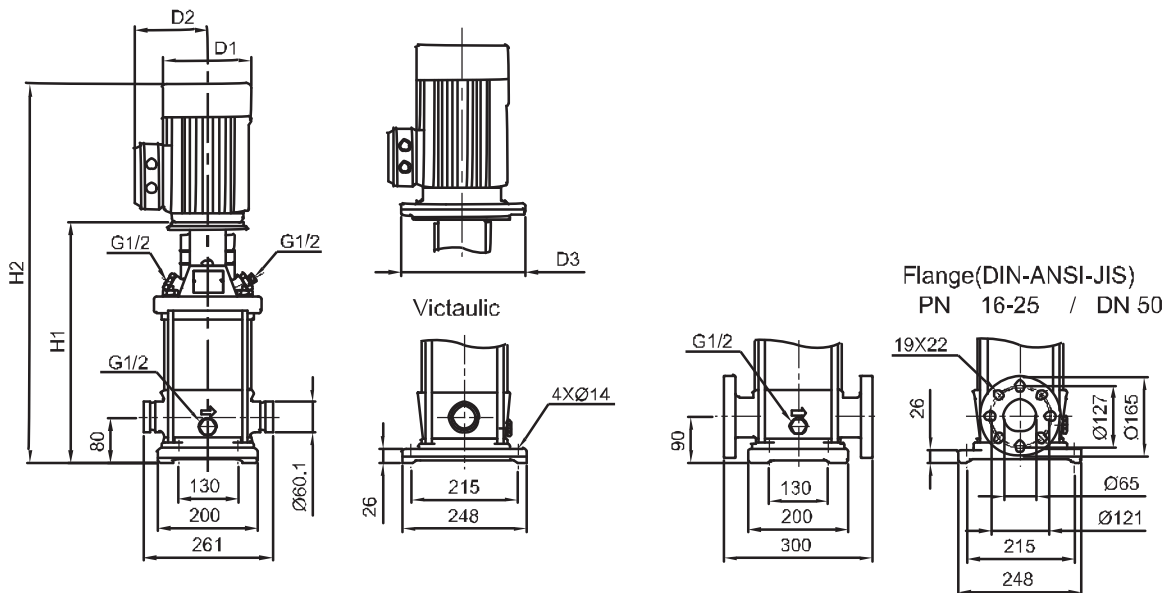

泵浦型號	電機 P ₂ [KW]	SBI,SBN								
		尺寸 (mm)							淨重 (kg)	
		Victaulic		DIN flange		D1	D2	D3	Victaulic	DIN flange
H1	H2	H1	H2							
SBI,SBN20-1	1.1	387	618	397	628	141	109	—	34	39
SBI,SBN20-2	2.2	403	678	413	688	175	140	—	44.3	48.8
SBI,SBN20-3	4	453	788	463	798	219	162	—	58.5	63.0
SBI,SBN20-4	5.5	530	890	540	900	234	199	300	84.8	89.3
SBI,SBN20-5	5.5	575	935	585	945	234	199	300	86.2	90.7
SBI,SBN20-6	7.5	620	1020	630	1030	234	199	300	96.6	101.1
SBI,SBN20-7	7.5	665	1065	675	1075	234	199	300	98.0	102.5
SBI,SBN20-8	11	787	1232	797	1242	265	215	350	129.6	134.1
SBI,SBN20-10	11	877	1322	887	1332	265	215	350	132.4	136.9
SBI,SBN20-12	15	967	1456	977	1466	265	215	350	146.2	150.7
SBI,SBN20-14	15	1057	1546	1067	1556	265	215	350	149.0	153.5
SBI,SBN20-17	18.5	1192	1727	1202	1737	317	242	350	188.2	192.7