

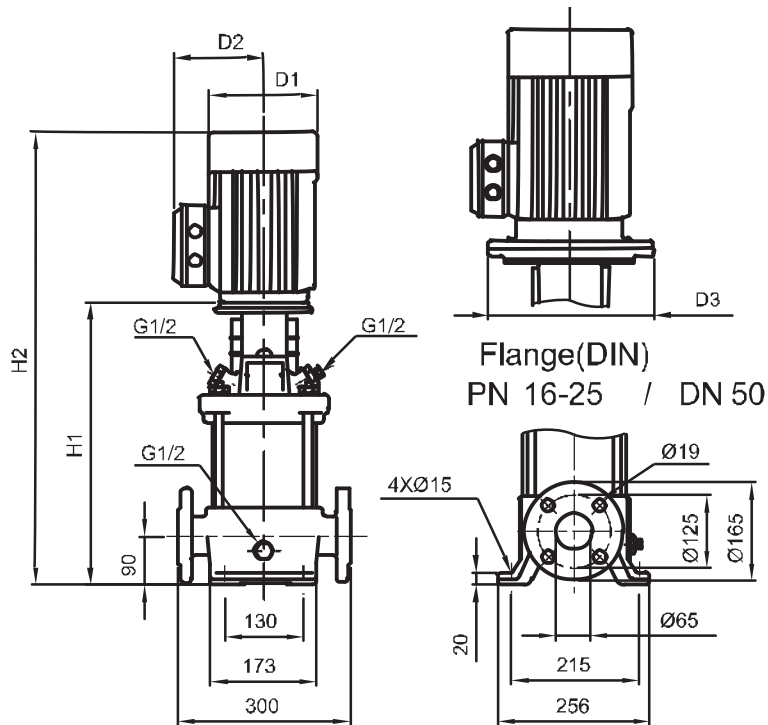

尺寸和重量-SB15



泵浦型號	電機	SB					
		尺寸 (mm)					淨重 (kg)
	P ₂ [KW]	DIN flange		D1	D2	D3	DIN flange
	H1	H2					
SB15-1	1.1	400	631	141	109	—	42
SB15-2	2.2	415	690	175	140	—	52.6
SB15-3	3	465	785	196	148	—	61.3
SB15-4	4	510	845	219	162	—	69.7
SB15-5	4	555	890	219	162	—	71.7
SB15-6	5.5	632	992	234	199	300	96.3
SB15-7	5.5	677	1037	234	199	300	97.7
SB15-8	7.5	722	1122	234	199	300	108.1
SB15-9	7.5	767	1167	234	199	300	109.5
SB15-10	11	889	1334	268	215	350	140.6
SB15-12	11	979	1424	268	215	350	143.4
SB15-14	11	1069	1514	268	215	350	146.2
SB15-17	15	1204	1693	268	215	350	161.4



尺寸和重量-SBI,SBN15

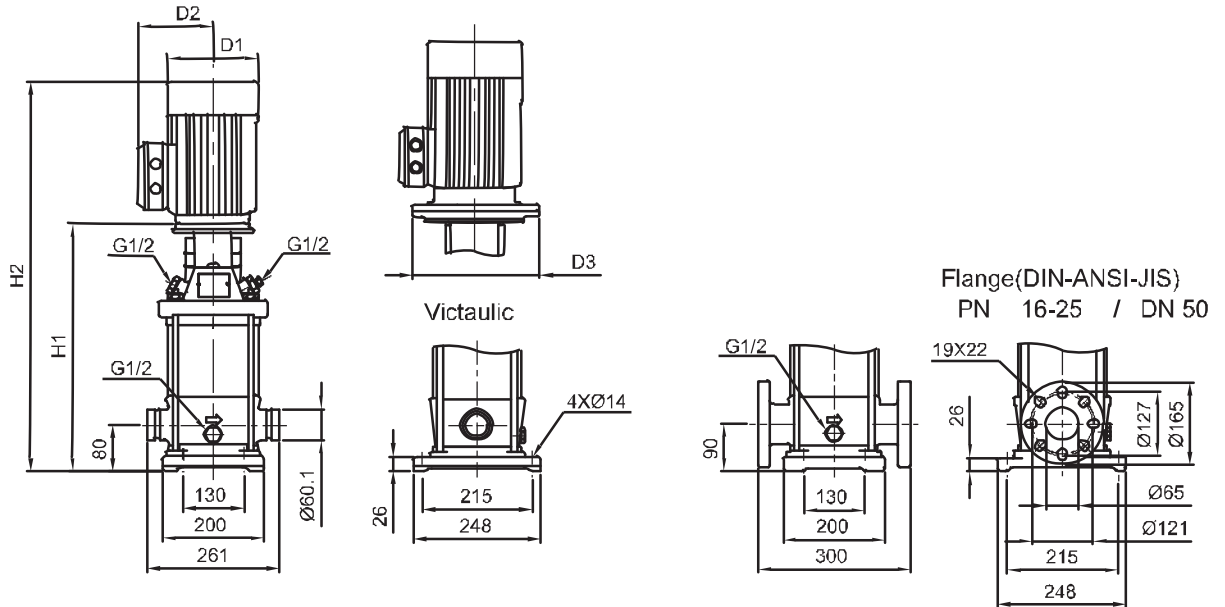

泵浦型號	電機 P ₂ [KW]	SBI,SBN								
		尺寸 (mm)						淨重 (kg)		
		Vitaulic		DIN flange		D1	D2	D3	Vitaulic	DIN flange
H1	H2	H1	H2							
SBI,SBN15-1	1.1	387	618	397	628	141	109	—	34	42
SBI,SBN15-2	2.2	403	678	413	688	175	140	—	44.3	48.8
SBI,SBN15-3	3	453	773	463	783	196	148	—	51.5	56.0
SBI,SBN15-4	4	498	833	508	843	219	162	—	59.9	64.4
SBI,SBN15-5	4	543	878	553	888	219	162	—	61.3	65.8
SBI,SBN15-6	5.5	620	980	630	990	234	199	300	87.6	92.1
SBI,SBN15-7	5.5	665	1025	675	1035	234	199	300	89.0	93.5
SBI,SBN15-8	7.5	710	1110	720	1120	234	199	300	99.4	103.9
SBI,SBN15-9	7.5	755	1155	765	1165	234	199	300	100.8	105.3
SBI,SBN15-10	11	877	1322	887	1332	268	215	350	132.4	136.9
SBI,SBN15-12	11	967	1412	977	1422	268	215	350	135.2	139.7
SBI,SBN15-14	11	1057	1502	1067	1512	268	215	350	138.0	142.5
SBI,SBN15-17	15	1192	1681	1202	1691	268	215	350	153.2	157.7